

# CARES

CRITICAL AREA RECIRCULATION/EXHAUST SYSTEM



# CARES

## Critical Area Recirculation/Exhaust System

The Critical Area Recirculation/Exhaust System (CARES) is a single 48 in. x 48 in. airflow device that combines the capabilities of a reverse flow Fan Filter Unit (FFU) with a one-way, flush face radial flow diffuser to manage the airflow for an entire patient room.

Traditionally hospitals are built with very few negative pressure isolation rooms as these spaces are seldom used and are more expensive to build and operate than standard patient rooms. The patented (pat. 2023/0083631) CARES is a critical component of the isolation-ready patient room solution from Price and Antec Controls that allows hospitals to build one room that can be used for standard patient care or converted to a negative pressure isolation room at the touch of a button.

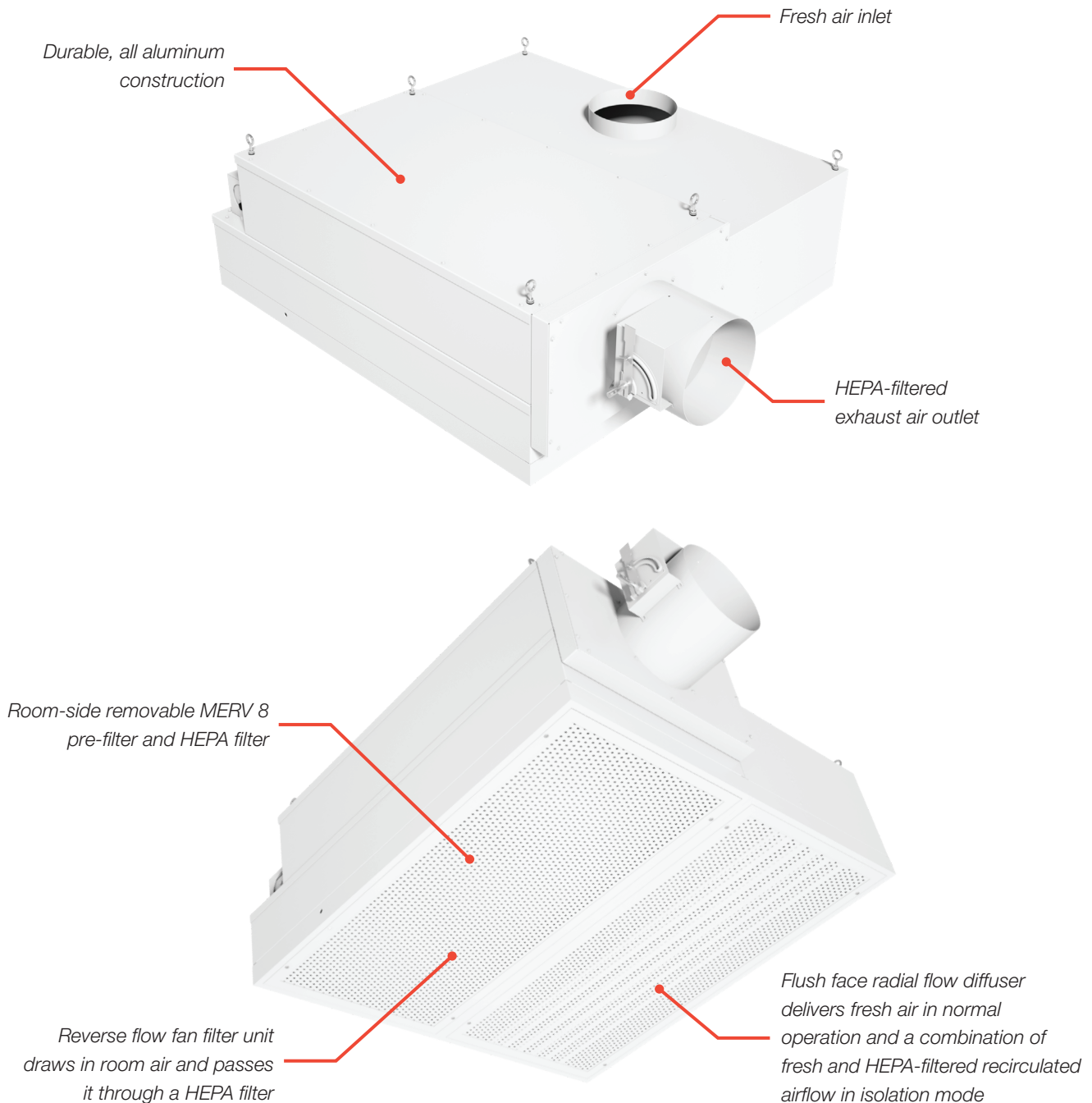

## CHANGE FROM NORMAL TO ISOLATION MODE

- + The CARES provides operational flexibility, allowing the hospital patient room to operate in normal mode for day-to-day use, or in isolation mode.
- + Fast conversion of a standard patient room to a negative pressure isolation room, eliminates the need for time consuming and unsightly field modifications in response to a surge in demand for isolation spaces.

## AIRFLOW FOR THE ENTIRE PATIENT ROOM

- + The CARES combines the capabilities of a reverse flow FFU with a one-way, flush face radial flow diffuser.
- + The flush face radial flow diffuser, commonly used in isolation rooms where short throw and high airflow capacity are required, provides a high level of dilution while producing low initial face velocity to maintain occupant comfort.
- + The reverse flow fan filter unit draws in room air, passes it through a MERV 8 pre-filter to remove larger particulate from the airstream, and then through a HEPA filter to remove 99.99% of particulate.

## TYPICAL APPLICATIONS

The CARES is designed specifically for hospital patient rooms. This product provides an all-in-one airflow solution for isolation-ready patient rooms, allowing the hospital to change from standard operation of the patient room to isolation mode.

### OPTIONS

- + Filter
  - HEPA
  - ULPA
- + Options
  - MERV 8 pre-filter
  - LED indicator
  - BACnet control
  - Roomside accessible controls

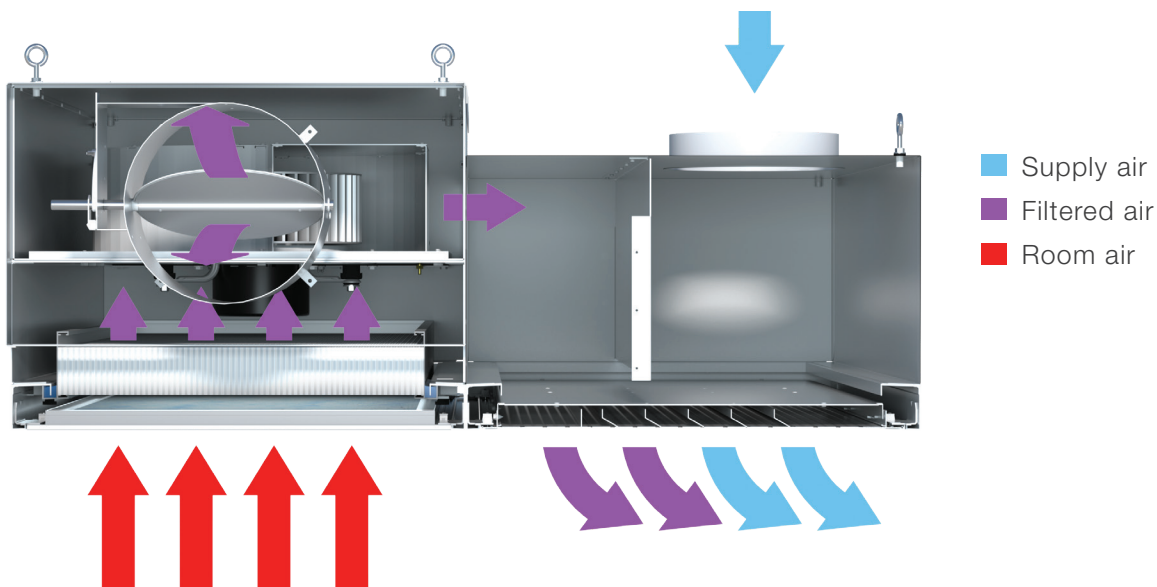

# ISOLATION-READY PATIENT ROOMS

## Room Requirements

ASHRAE Standard 170-2017 Ventilation of Health Care Facilities dictates the following requirements for standard patient rooms and isolation rooms. In the proposed isolation-ready layouts on the following pages “Normal Operation” aligns with the ASHRAE Standard 170 requirements for “Standard Patient Rooms” while “Isolation Mode” aligns with the ASHRAE Standard 170 operational requirements of an “Isolation Room”.

	Standard Patient Room	Isolation Room
Airflow - Outdoor	2 ACH	2 ACH
Airflow - Total	4 ACH	12 ACH
Pressure Differential	No requirement	-0.01 in. w.g. pressure monitor required
Exhaust	Washroom exhaust	Washroom exhaust and room exhaust located near patient head.
Return	Room return grille located near door	Return not allowed
Recirculation	Allowed	Only allowed if room air is recirculated locally through a HEPA filter
Supply Diffuser	Not specified	Located near entry door. Air moves from clean to less-clean.

## OPERATION

With the above guidelines in mind, the Price isolation-ready patient room solution is capable of meeting the air distribution needs of both standard patient rooms and negative pressure isolation rooms by creating 0.1 in.w.g negative pressure and increasing from 4 to 12 Air Changes per Hour (ACH) in isolation mode. This is accomplished through strategic placement of the CARES, exhausting air to create negative pressure and locally recirculating HEPA filtered air to increase the air change rate.

The BACnet MS/TP capable Room Pressure Monitor (PMT) from Antec Controls satisfies the ASHRAE 170 requirements for a permanently installed pressure-monitoring device that indicates if pressure differential drops below required levels, completing the isolation-ready patient room package.

**In normal operation** fresh supply air is distributed to the room through the flush face radial flow diffuser component of the CARES, while room air is returned to the central air handler.

**In isolation mode,** room air is drawn in through the face of the reverse flow fan filter unit and passed through a MERV 8 pre-filter and HEPA filter before a portion of the airflow is exhausted to create negative room pressure. The remainder of the filtered air is recirculated to the space through the integrated flush face radial flow diffuser. The integral flush face radial flow diffuser is also used to distribute fresh air from the airhandler. This multi-purpose unit greatly simplifies the planning and construction of an isolation-ready patient room.

# CARES

## Critical Area Recirculation/Exhaust System

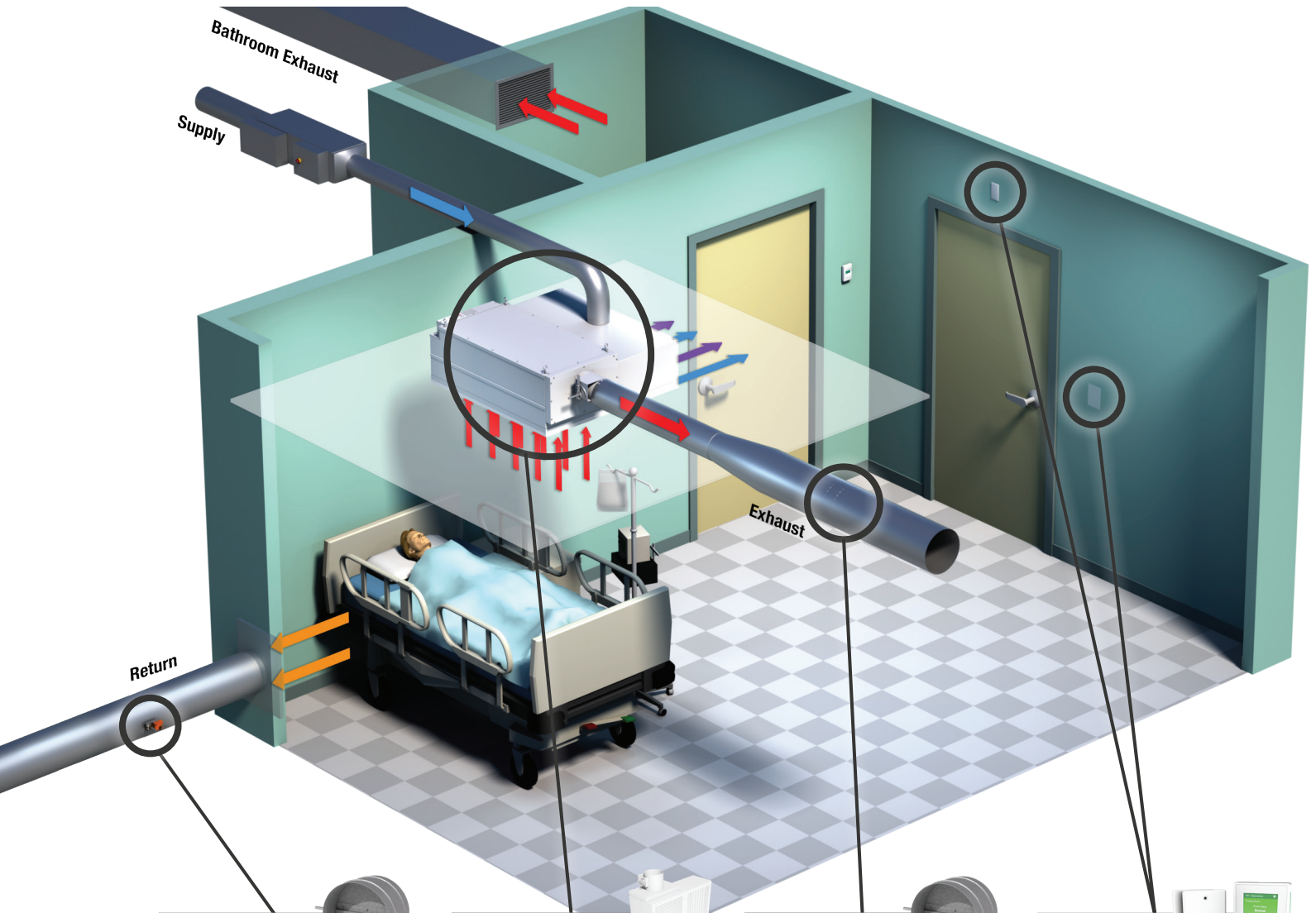

### Return Damper/Actuator

- **Normal Operation:** Damper open to allow return airflow to the air handler.
- **Isolation Mode:** Damper closed to prevent return airflow to the air handler.

### Critical Area Re-Circulation/Exhaust System (CARES)

- **Normal Operation:** Fresh air supplied to room.
- **Isolation Mode:** Room air is drawn in through the face of the CARES and passed through a HEPA filter before a portion of the airflow is exhausted and the remainder is locally recirculated.

### Exhaust Damper/Actuator

- **Normal Operation:** Damper closed.
- **Isolation Mode:** Damper opens to exhaust air and create negative room pressure.

### Room Pressure Monitor (PMT)

- **Normal Operation:** No room pressure requirement.
- **Isolation Mode:** Measures and displays room pressure. Activates FFU, closes return damper, opens exhaust damper to create negative room pressure.

# CARES

## Critical Area Recirculation/Exhaust System

### ENERGY EFFICIENT

- + The flexibility of the CARES allows a patient room to be operated as an isolation room only in times of need, conserving the energy associated with high air change rates during normal operation.
- + Room-level control of room pressure and air change rates allows for room-level energy expenditure, reducing overall energy consumption when compared to building wide systems.



### ROOM-SIDE FILTER AND MOTOR STATUS

An optional face-mounted color LED alerts the user when the filter is loaded and due for replacement, or if the motor is not operating properly. A green LED indicates normal operation, a yellow LED indicates a loaded filter and a red LED indicates an issue with the motor. The loaded filter setpoint can be field adjusted to suit individual needs.

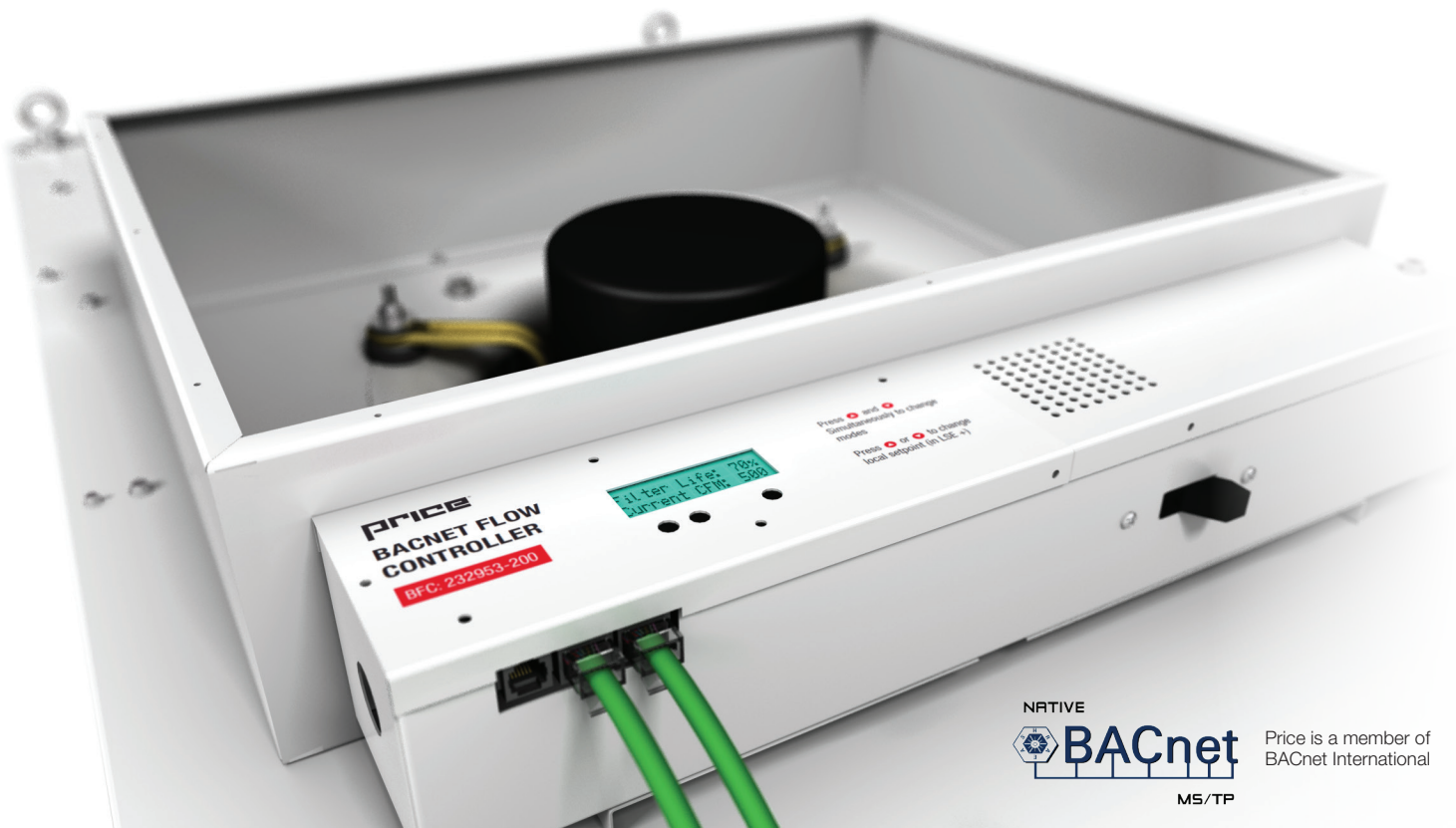

### BACNET FLOW CONTROLLER

The BACnet Flow Controller (BFC) offers seamless integration with BACnet building networks for unmatched control monitoring of the CARES. The optional BACnet flow controller allows for individual or large groupings of CARES units to be changed over from normal to isolation mode at the touch of a button, in one convenient location.

### Key Features

- + Native BACnet MS/TP
- + Backlit LCD display
- + Several network points for control, monitoring or trending:
  - CFM output
  - Motor RPM & status
  - Motor hours
  - Filter status & pressure drop
  - Filter hours

### EASY MAINTENANCE FROM THE ROOM SIDE

- + Quickly and easily replace both the HEPA filter, and optional MERV 8 pre-filter from the room-side.
- + Integrated knife edge and HEPA filter gel track prevent filter bypass and allow for tool-free installation and replacement.
- + Optional MERV 8 pre-filter captures large particulate, extending the life of the more costly HEPA filter.
- + Room-side removable motor/blower assembly for easy maintenance or replacement.

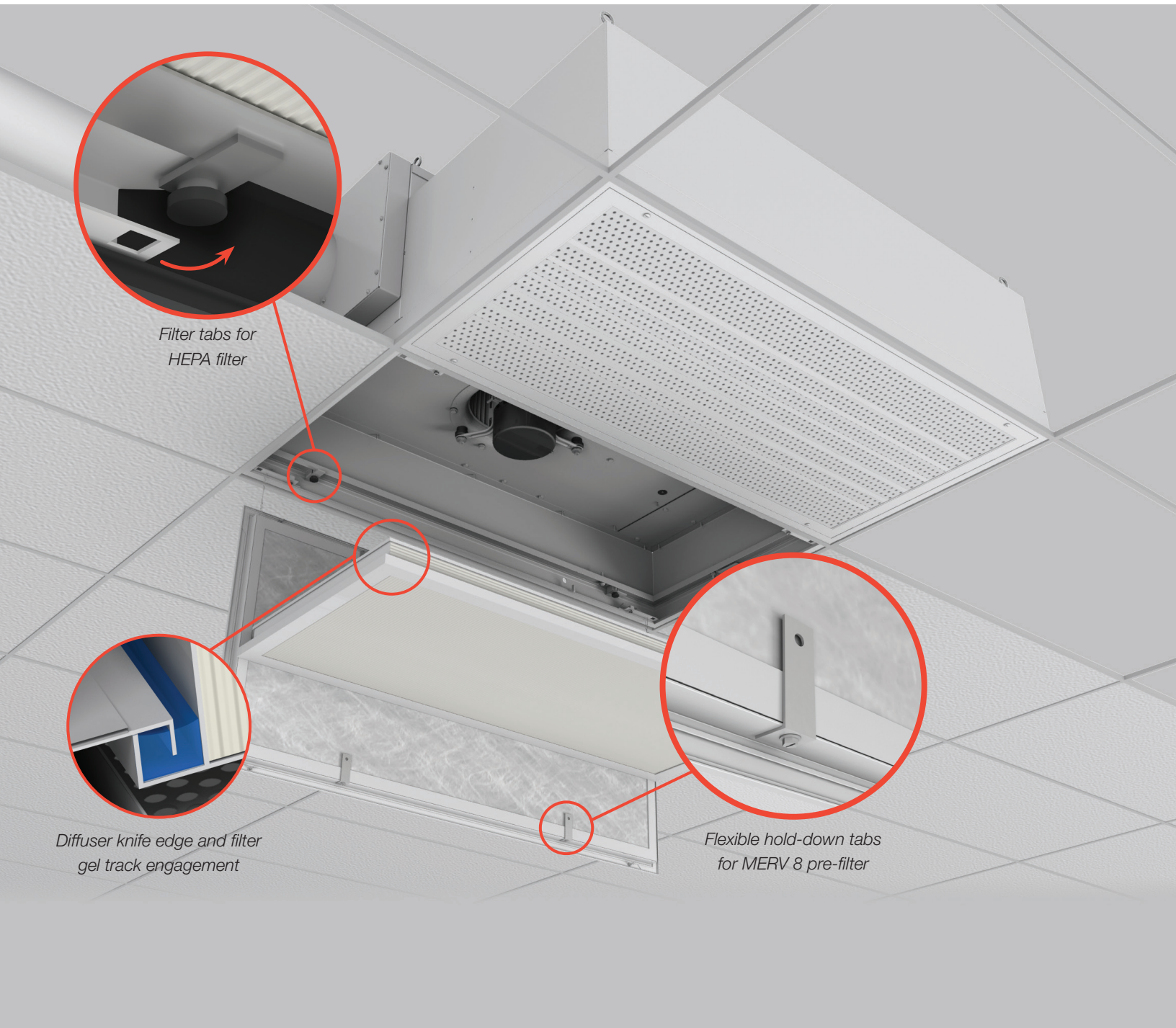

*Filter tabs for  
HEPA filter*

*Diffuser knife edge and filter  
gel track engagement*

*Flexible hold-down tabs  
for MERV 8 pre-filter*



## DIMENSIONAL DATA

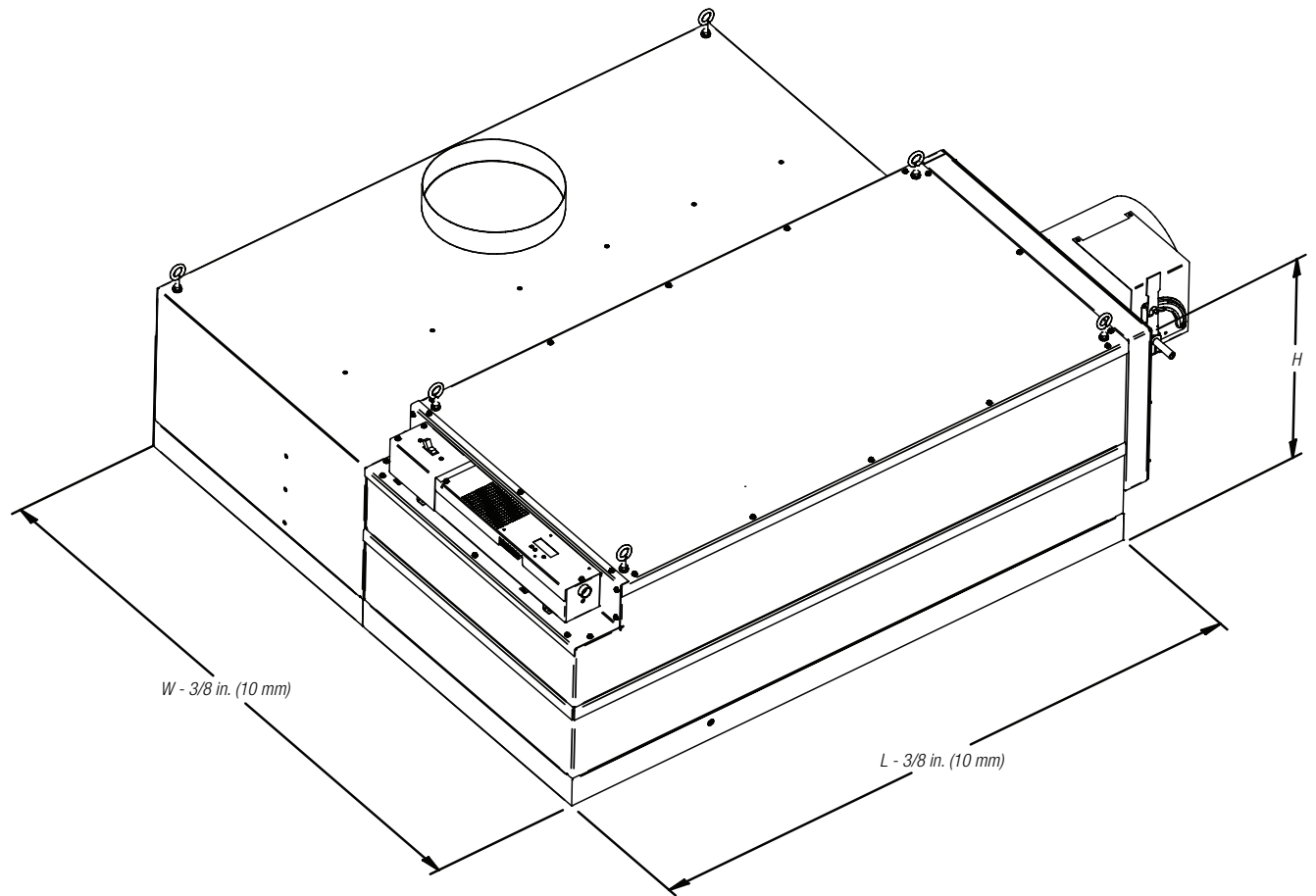

Nominal Unit Size (W x L)	Actual Width	Actual Length	Actual Height
48 in. x 48 in.	47.63 in.	47.63 in.	18.00 in.
1200 mm x 1200 mm	1190 mm	1190 mm	457 mm

## PERFORMANCE DATA

### Imperial

Airflow (CFM)	Velocity (FPM)	Power Consumption (W)
275	50	45
375	70	65
475	90	100
575	110	145
675	130	210

**Performance Notes:**

1. Units are tested in accordance with IEST RP-CC002.2, Recommended Practice for Unidirectional Flow Clean-Air Devices.
2. For electrical circuit sizing, consult the "max amps" shown on the submittal for each product configuration and voltage.
3. All data is based on a unit with a clean HEPA filter.
4. FPM values are based on active filter area.
5. Heat Gain: BTUh = Watts x 3.413

## PERFORMANCE DATA

### Metric

Airflow (L/s)	Velocity (m/s)	Power Consumption (W)
130	0.25	45
177	0.36	65
224	0.46	100
271	0.56	145
319	0.66	210

#### Performance Notes:

1. Units are Tested in accordance with IEST RP-CC002.2, Recommended Practice for Unidirectional Flow Clean-Air Devices.
2. For electrical circuit sizing, consult the "max amps" shown on the submittal for each product configuration and voltage.
3. All data is based on a unit with a clean filter.
4. Velocity (m/s) values are based on active filter area.











Product Improvement is a continuing endeavour at Price. Therefore, specifications are subject to change without notice. Consult your Price Sales Representative for current specifications or more detailed information. Not all products may be available in all geographic areas. All goods described in this document are warranted as described in the Limited Warranty shown at [priceindustries.com](http://priceindustries.com). The complete Price product catalog can be viewed online at [priceindustries.com](http://priceindustries.com).